

CAMBRIDGE INTERNATIONAL EXAMINATIONS
General Certificate of Education Advanced Subsidiary Level
General Certificate of Education Advanced Level

MATHEMATICS

9709/1

PAPER 1 Pure Mathematics 1 (P1)

MAY/JUNE SESSION 2002

1 hour 45 minutes

Additional materials:
Answer paper
Graph paper
List of Formulae (MF9)

TIME 1 hour 45 minutes

INSTRUCTIONS TO CANDIDATES

Write your name, Centre number and candidate number in the spaces provided on the answer paper/answer booklet.

Answer **all** the questions.

Give non-exact numerical answers correct to 3 significant figures, or 1 decimal place in the case of angles in degrees, unless a different level of accuracy is specified in the question.

INFORMATION FOR CANDIDATES

The number of marks is given in brackets [] at the end of each question or part question.

The total number of marks for this paper is 75.

Questions carrying smaller numbers of marks are printed earlier in the paper, and questions carrying larger numbers of marks later in the paper.

The use of an electronic calculator is expected, where appropriate.

You are reminded of the need for clear presentation in your answers.

This question paper consists of 5 printed pages and 3 blank pages.

1 The line $x + 2y = 9$ intersects the curve $xy + 18 = 0$ at the points A and B . Find the coordinates of A and B . [4]

2 (i) Show that $\sin x \tan x$ may be written as $\frac{1 - \cos^2 x}{\cos x}$. [1]

(ii) Hence solve the equation $2 \sin x \tan x = 3$, for $0^\circ \leq x \leq 360^\circ$. [4]

3

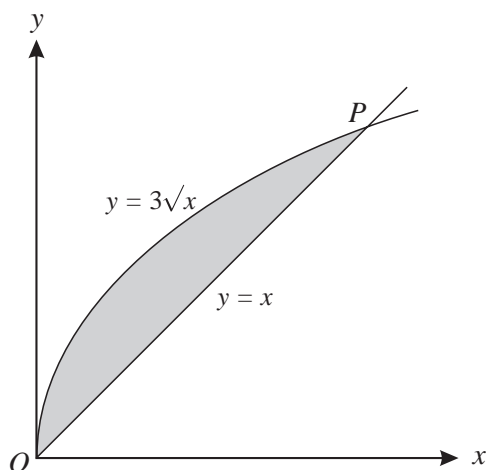

The diagram shows the curve $y = 3\sqrt{x}$ and the line $y = x$ intersecting at O and P . Find

(i) the coordinates of P , [1]

(ii) the area of the shaded region. [5]

4 A progression has a first term of 12 and a fifth term of 18.

(i) Find the sum of the first 25 terms if the progression is arithmetic. [3]

(ii) Find the 13th term if the progression is geometric. [4]

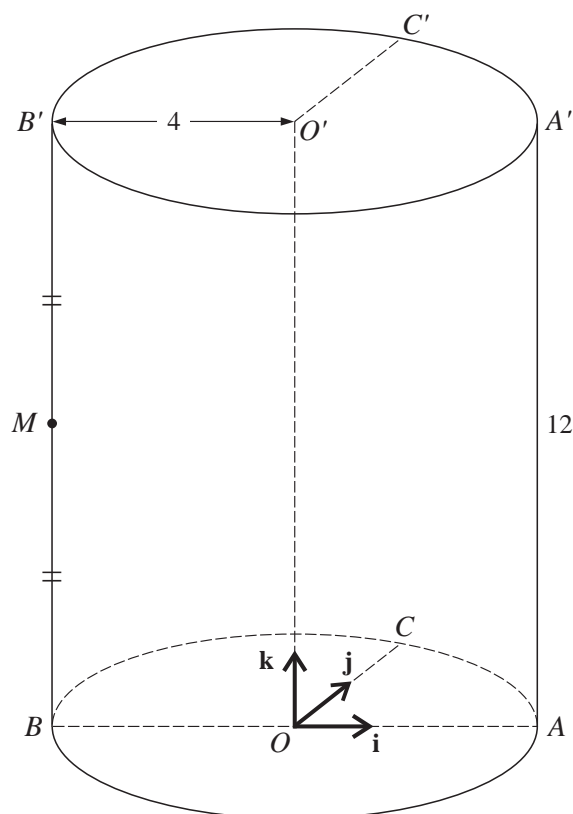

The diagram shows a solid cylinder standing on a horizontal circular base, centre O and radius 4 units. The line BA is a diameter and the radius OC is at 90° to OA . Points O' , A' , B' and C' lie on the upper surface of the cylinder such that OO' , AA' , BB' and CC' are all vertical and of length 12 units. The mid-point of BB' is M .

Unit vectors \mathbf{i} , \mathbf{j} and \mathbf{k} are parallel to OA , OC and OO' respectively.

(i) Express each of the vectors \overrightarrow{MO} and $\overrightarrow{MC'}$ in terms of \mathbf{i} , \mathbf{j} and \mathbf{k} . [3]

(ii) Hence find the angle OMC' . [4]

6 The function f , where $f(x) = a \sin x + b$, is defined for the domain $0 \leq x \leq 2\pi$. Given that $f(\frac{1}{2}\pi) = 2$ and that $f(\frac{3}{2}\pi) = -8$,

(i) find the values of a and b , [3]

(ii) find the values of x for which $f(x) = 0$, giving your answers in radians correct to 2 decimal places, [2]

(iii) sketch the graph of $y = f(x)$. [2]

7

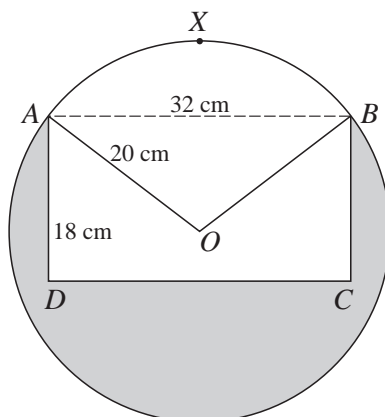

The diagram shows the circular cross-section of a uniform cylindrical log with centre O and radius 20 cm. The points A , X and B lie on the circumference of the cross-section and $AB = 32$ cm.

(i) Show that angle $AOB = 1.855$ radians, correct to 3 decimal places. [2]

(ii) Find the area of the sector $AXBO$. [2]

The section $AXBCD$, where $ABCD$ is a rectangle with $AD = 18$ cm, is removed.

(iii) Find the area of the new cross-section (shown shaded in the diagram). [3]

8 A hollow circular cylinder, open at one end, is constructed of thin sheet metal. The total external surface area of the cylinder is 192π cm². The cylinder has a radius of r cm and a height of h cm.

(i) Express h in terms of r and show that the volume, V cm³, of the cylinder is given by

$$V = \frac{1}{2}\pi(192r - r^3). \quad [4]$$

Given that r can vary,

(ii) find the value of r for which V has a stationary value, [3]

(iii) find this stationary value and determine whether it is a maximum or a minimum. [3]

9 A curve is such that $\frac{dy}{dx} = \frac{12}{(2x+1)^2}$ and $P(1, 5)$ is a point on the curve.

(i) The normal to the curve at P crosses the x -axis at Q . Find the coordinates of Q . [4]

(ii) Find the equation of the curve. [4]

(iii) A point is moving along the curve in such a way that the x -coordinate is increasing at a constant rate of 0.3 units per second. Find the rate of increase of the y -coordinate when $x = 1$. [3]

10 The functions f and g are defined by

$$f : x \mapsto 3x + 2, \quad x \in \mathbb{R},$$
$$g : x \mapsto \frac{6}{2x + 3}, \quad x \in \mathbb{R}, \quad x \neq -1.5.$$

- (i) Find the value of x for which $fg(x) = 3$. [3]
- (ii) Sketch, in a single diagram, the graphs of $y = f(x)$ and $y = f^{-1}(x)$, making clear the relationship between the two graphs. [3]
- (iii) Express each of $f^{-1}(x)$ and $g^{-1}(x)$ in terms of x , and solve the equation $f^{-1}(x) = g^{-1}(x)$. [5]

BLANK PAGE

BLANK PAGE

BLANK PAGE